

*WindowWellExperts.com*

# ***PRODUCT CATALOG***

---

*Window Wells*

*Window Well Covers*

*Egress Kits*



# TABLE OF CONTENTS



**WINDOW WELL COVERS**  
**PAGE 4 - 15**

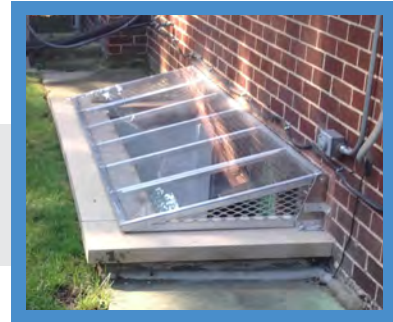

**SUPER SLANT**  
**PAGE 15**



**WINDOW WELLS**  
**PAGE 18 - 20**



**EGRESS KITS**  
**PAGE 22-23**



**EGRESS LADDERS**  
**PAGE 24**

**DECORATIVE LINERS**  
**PAGE 25**



**BASEMENT WINDOWS**  
**PAGE 26**

# WINDOW WELL COVERS



**SLOPED WINDOW WELL COVER**

4



**ATRIUM WINDOW WELL COVERS**

12



**FLAT WINDOW WELL COVER**

6



**CLEAR TOP COVERS FOR GRATES**

14

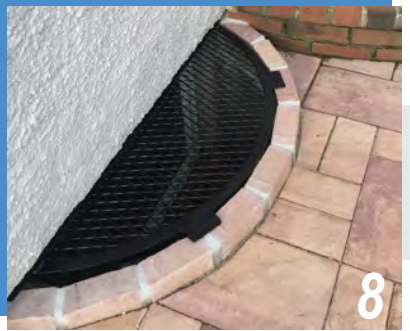

**WINDOW WELL GRATES**

8

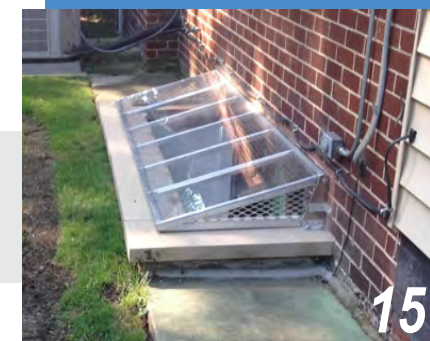

**SUPER SLANT COVERS**

15



**BUBBLE WINDOW WELL COVERS**

10

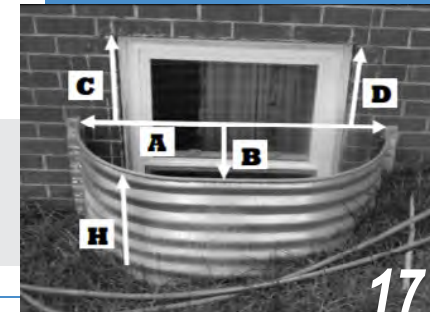

**MEASURING INSTRUCTIONS**

17

# SLOPED WINDOW WELL COVER

Every **Sloped Style** cover is custom designed to fit any shape, size, and type of window well. Polycarbonate window well covers by Window Well Experts provide the protection you need from the elements.

- ✓ Supports up to 400 pounds
- ✓ Crystal-clear Polycarbonate
- ✓ UV-coated to prevent yellowing
- ✓ Custom-fit to YOUR well perfectly



 Free Estimate

Interested in our Custom Window Well Covers? [Click here to get a quote](#)

[Get a Free Estimate](#)

Our **Sloped Style** window well covers are made to shed water away from your home, and rain or a rinse with your garden hose washes the dirt and debris away, leaving them clean and clear.

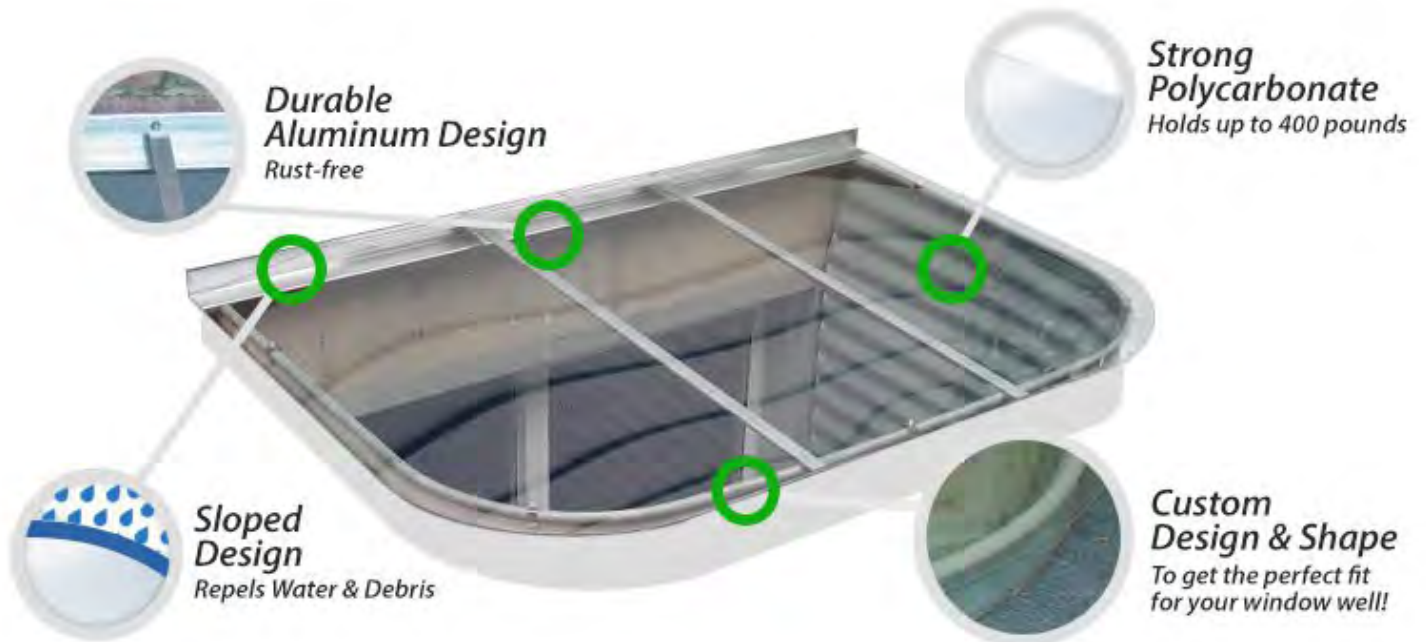

**Sloped Window Well Covers** are made from UV coated unbreakable polycarbonate that is lightweight, allows the maximum amount of light into your basement, and allows easy egress in case of emergency.

Our Sloped cover safely supports 400 pounds. Its clamshell design makes it self-cleaning—sheds water and debris away from your home.

Our covers keep snow and rain, dirt, yard debris and animals out of your window well. They are made to fit your window wells, not someone else’s idea of “standard”.



**THIS COVER STYLE INCLUDES A LIFETIME WARRANTY**

The Lifetime Warranty on our Flat Window Well Covers protects your covers from:

- Broken aluminum parts, hinges, or locks
- Cracks or splits in the Polycarbonate cover
- Broken clips that attach the cover to the well

Find out more information on our Lifetime Warranty by [clicking here](#).

# FLAT WINDOW WELL COVER

This low-profile polycarbonate window well cover is custom-designed to fit any shape, size, and type of window well.

- ✓ Supports up to 400 lbs
- ✓ Crystal-clear
- ✓ UV-coated
- ✓ Custom-fit to YOUR well perfectly



Interested in our Custom Window Well Covers? [Click here to get a quote](#)

[Get a Free Estimate](#)

Our **Flat Window Well Covers** are made from high-strength polycarbonate and not the cheap plastic you find in stores. Each cover is UV treated to protect your cover from yellowing.

- ✓ Safely supports 400 pounds
- ✓ Keeps snow and rain, dirt, yard debris and animals out of your window well.
- ✓ Is made to fit your window wells, not someone else's idea of "standard".

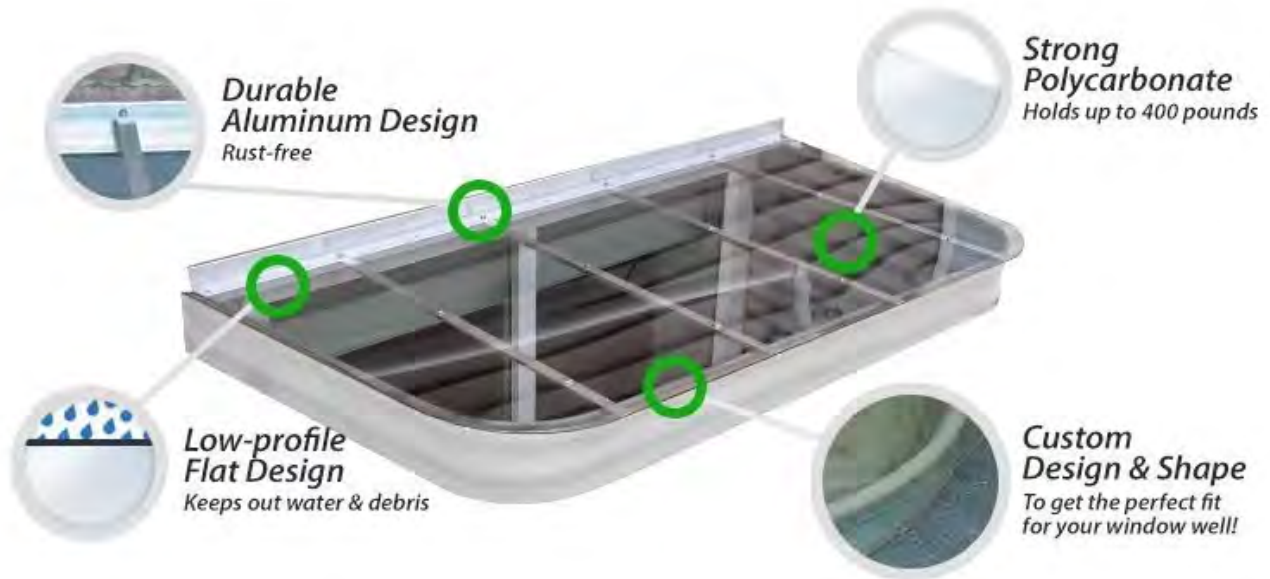

#### THIS COVER STYLE INCLUDES A LIFETIME WARRANTY

The Lifetime Warranty on our Flat Window Well Covers protects your covers from:

- Broken aluminum parts, hinges, or locks
- Cracks or splits in the Polycarbonate cover
- Broken clips that attach the cover to the well

Find out more information on our Lifetime Warranty by [clicking here](#).

Interested in our Custom Window Well Covers? [Click here to get a quote](#)

[Get a Free Estimate](#)

# WINDOW WELL GRATES

Custom fabricated steel and aluminum **window well grates** fit your window well exactly and can support up to 400 pounds.

- ✓ Rust-free Aluminum Design
- ✓ Custom-fit to YOUR well perfectly
- ✓ Includes 7 year Warranty



Interested in our Custom Window Well Covers? [Click here to get a quote](#)

[Get a Free Estimate](#)



**Window well grates** are made from high quality, rust free aluminum that is light weight for safety and easy removal. Our window well grates can be made to match any style, shape, and size of window well.

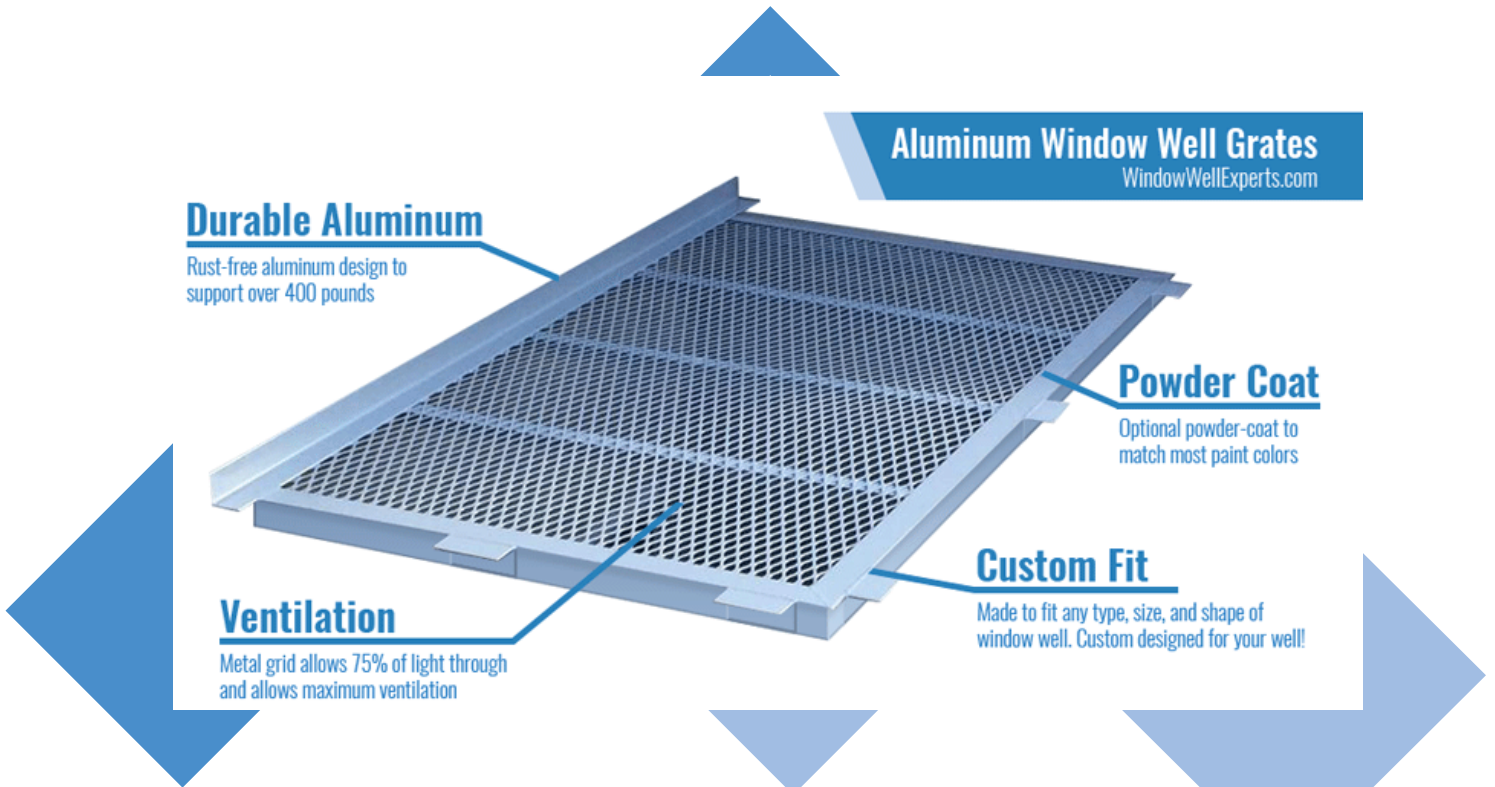

- ✓ Safely supports 400 lbs.
- ✓ Ideal where easy fresh air ventilation is desired.
- ✓ Can be custom made for all sizes of window wells, including metal, plastic composite, concrete, landscape timber, and landscape block.
- ✓ Clear top covers for grates can be used on your existing grate or with our lightweight aluminum grate.

**ALUMINUM GRATES AVAILABLE IN SELECT POWDER-COAT FINISHES:**



Un-Finished Aluminum



White



Grey



Black



Custom Powder-Coat  
(available in most colors)

# BUBBLE WINDOW WELL COVERS

**Bubble Window Well Covers** by Window Well Experts are made from unbreakable polycarbonate, not cheap plastic like the big box stores.

- ✓ Crystal-clear Polycarbonate
- ✓ Designed for windows that extend above the well
- ✓ Wide variety of sizes to fit most wells!



Interested in our Custom Window Well Covers? [Click here to get a quote](#)

[Get a Free Estimate](#)

Our **Bubble window well covers** are fabricated of the same high quality polycarbonate that we use on our custom window well covers! Call us for a full range of sizes -- 888-650-WELL (9355).

## HIGH QUALITY BUBBLE WINDOW WELL COVERS

Bubble Domes are commonly the first style of cover most people think of when they think of the phrase “window well covers”. Our Bubble window well covers are made of the same tough, unbreakable polycarbonate plastic that our other clear covers are fabricated from—not the cheaper Plexiglas or acrylic that some store’s covers are made of. They won’t shatter on impact from a stray rock, baseball bat, or by a weed whip getting too close. They withstand the sun’s UV rays, and the stresses of heat and cold without cracking.

We have a wide size range available, and more sizes being made on a regular basis; all of them produced in the USA. We ship throughout the USA and Canada. The hardware to attach the bubbles to your home are rust free stainless steel and are designed to snap off to allow for easy access to your window well for any necessary maintenance.

Like our Atrium domes, our Bubble domes are designed to bear the weight of an adult falling on them without falling through.



# ATRIUM WINDOW WELL COVERS

Our *Atrium Dome* clear window well covers are designed to cover your window above the top of your window well. We make these covers to your specific needs. Many customers prefer this cover just for the good looks of it!

- ✓ Crystal-clear Polycarbonate
- ✓ Custom-fit to YOUR well perfectly
- ✓ 7 Year Warranty
- ✓ Accommodates crank out windows for easy emergency escape

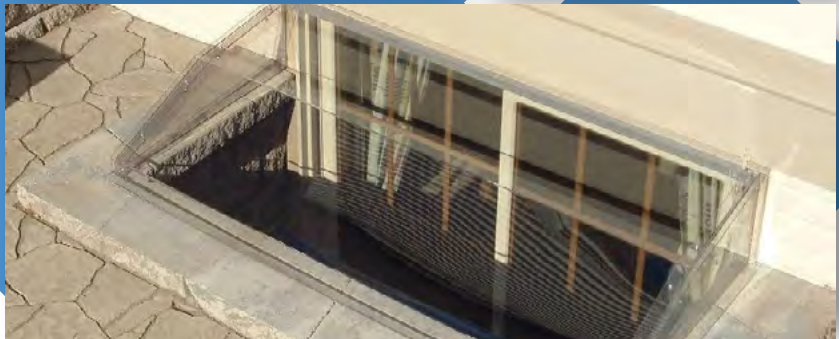

Interested in our Custom Window Well Covers? [Click here to get a quote](#)

[Get a Free Estimate](#)

## ATRIUM DOME CLEAR WINDOW WELL COVERS

These covers are designed to accommodate casement/crank-out style windows that need a special cover, because low profile style covers prevent the window from opening out into the well for emergency escape.

These clear window well covers are customizable to any width, projection, and height. If you have a crank-out or casement window, this dome is designed for you. Another advantage to this cover is the unobstructed view—on most covers there is no bracing in your line of sight. The polycarbonate plastic is strong enough to withstand an adult falling on the cover without falling through. We have made these covers with mesh fronts and sides to allow for ventilation for air conditioning units and other machinery.

We have a cover to suit any need. Please contact us for assistance or to learn more about our Atrium clear window well covers –888-650-WELL (9355).



# CLEAR TOP COVERS FOR GRATES

Made to fit on top of any Window Well Grate to provide extra protection from rain and debris. Fabricated from unbreakable polycarbonate. Easily removable for ventilation!

- ✓ Fits over any Window Well Grate
- ✓ Ultra-strong Polycarbonate
- ✓ Custom made to fit YOUR grate perfectly



# SUPER SLANT

Our **Super Slant** covers are custom-made to fit YOUR well, it provides superb drainage, and protection from debris. Holds 400 pounds. Our best cover with the highest number of options available.

- ✓ Steep design for optimal drainage
- ✓ Ultra-strong Polycarbonate
- ✓ Custom made to fit YOUR well perfectly
- ✓ Rust-free aluminum support
- ✓ Quick-release lock system
- ✓ Top is hinged with prop-up bar for easy access
- ✓ Escape hatches available for extra large covers



# SUPER SLANT

Our unique **Super Slant** model is made of high-grade polycarbonate (the bullet-resistant type). This quality plastic has a special UV formula. As a result, it will not turn yellow over time, even if it's exposed to the merciless summer sun all year round. The plastic in the cover has more than 20 years of longevity.

Along with the "unbreakable plastic," these heavy-duty window well covers have a sturdy aluminum frame structure. The rust-free material is durable and, more importantly, lightweight. This allows even children and the elderly to lift the cover with ease in case of emergency.

## INCLUDED IN THE SUPER SLANTED COVER PRICE:

- Custom-Fitted Polycarbonate Window Well Cover
- Aluminum Framing
- Hinge And Prop-Up Bar For Easy Open
- Locking System For The Cover
- Warranty – 7 Years
- Optional: Aluminum Mesh Sides For Ventilation





## WINDOW WELL COVER MEASURING GUIDE

# Window Well Measuring Guide

Determine the material of your window well and if your window is below or above your window well.

Submit your measurements online at [WindowWellExperts.com/submit](http://WindowWellExperts.com/submit) or call us at 1-888-650-9355

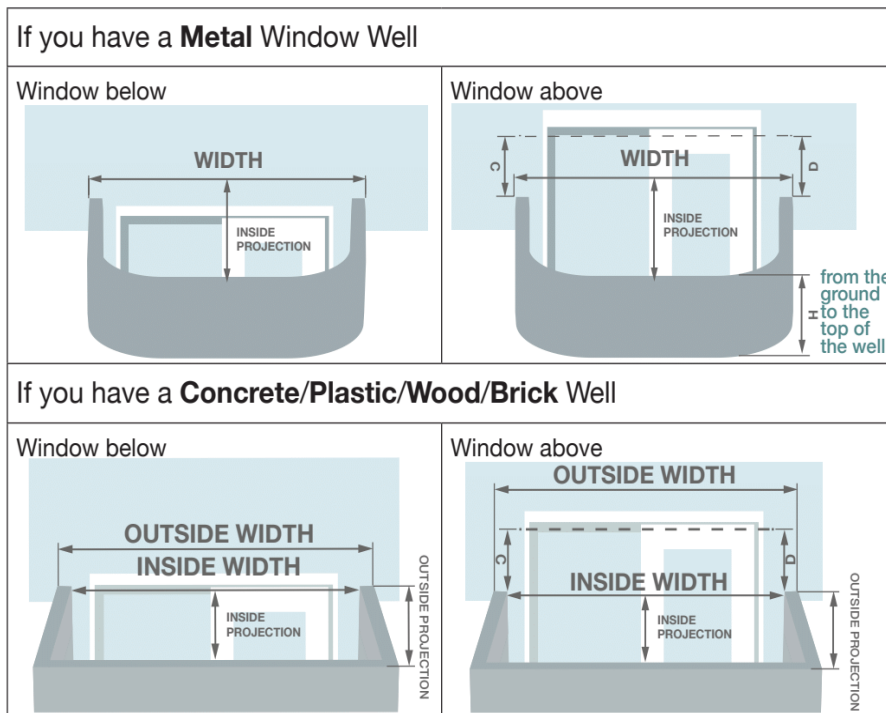

### IMPORTANT

For **METAL WELLS**, measure to the outside lip of your well to the nearest 1/8th inch.





For **CONCRETE/PLASTIC/WOOD/BRICK WELLS**, measure the outside dimensions of your well to the outer edge. Then measure the inside dimensions to the inner edge.

**INSIDE PROJECTION** - Measure from the wall of the house (as shown on the graphics).

For **OUTSIDE PROJECTION**, measure from the wall to the outer edge of the well.

**C & D** - Measure the right and left side of the well, from the top of well to top of the window glass.

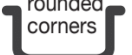
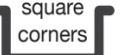
**H** - Distance from the well lip to the ground for metal wells.

|                     |                    |   |   |  |   |   |
|---------------------|--------------------|---|---|--|---|---|
| Circle the relevant | Material           | metal   | concrete  | plastic  | wood  | paver/brick   |
|                     | If Window is above | slider  | crankout  | awning   | other:  |   |
|                     | Shape              |  |  |  |  |  |

| Well (all in inches)            | #1    | #2    | #3    | #4    | #5    | #6    | #7    |
|---------------------------------|-------|-------|-------|-------|-------|-------|-------|
| Window Above/Below (Circle One) | A / B | A / B | A / B | A / B | A / B | A / B | A / B |
| Outside Width                   |       |       |       |       |       |       |       |
| Inside Width                    |       |       |       |       |       |       |       |
| B (Projection)                  |       |       |       |       |       |       |       |
| Outside Projection              |       |       |       |       |       |       |       |
| Dimension C (if Above)          |       |       |       |       |       |       |       |
| Dimension D (if Above)          |       |       |       |       |       |       |       |
| Dimension H (if Metal well)     |       |       |       |       |       |       |       |

# WINDOW WELLS

**Galvanized steel window wells:** We proudly provide all sizes and shapes available in a wide variety of sizes--see the charts below. Most wells have a 30 year warranty! We will be glad to help you find the right size for any situation you have. Call an Expert for help at 888-650-9355.

## GALVANIZED WINDOW WELLS



| Casement Square 24" | Gauge | Width | Projection | Available Depths                       |
|---------------------|-------|-------|------------|--|
| WCS3724             | 18"   | 37"   | 24"        | 12", 18", 24", 30", 36", 48", 60", 72" |
| WCS4224             | 18"   | 42"   | 24"        | 12", 18", 24", 30", 36", 48", 60", 72" |
| WCS4824             | 18"   | 48"   | 24"        | 12", 18", 24", 30", 36", 48", 60", 72" |
| WCS5524             | 18"   | 55"   | 24"        | 12", 18", 24", 30", 36", 48", 60", 72" |
| WCS6324             | 18"   | 63"   | 24"        | 12", 18", 24", 30", 36", 48", 60", 72" |
| WCS7224             | 18"   | 72"   | 24"        | 12", 18", 24", 30", 36", 48", 60", 72" |

## EGRESS WINDOW WELLS



| 36" Egress Well | Gauge | Width | Projection | Available Depths                            |
|-----------------|-------|-------|------------|---|
| WCS4236         | 18"   | 42"   | 36"        | 12", 18", 24", 36", 48", 60", 72", 84", 96" |
| WCS5036         | 18"   | 50"   | 36"        | 12", 18", 24", 36", 48", 60", 72", 84", 96" |
| WCS5536         | 18"   | 55"   | 36"        | 12", 18", 24", 36", 48", 60", 72", 84", 96" |
| WCS6036         | 18"   | 60"   | 36"        | 12", 18", 24", 36", 48", 60", 72", 84", 96" |
| WCS6736         | 18"   | 67"   | 36"        | 12", 18", 24", 36", 48", 60", 72", 84", 96" |
| WCS7536         | 18"   | 75"   | 36"        | 12", 18", 24", 36", 48", 60", 72", 84", 96" |
| WCS8036         | 16"   | 80"   | 36"        | 12", 18", 24", 36", 48", 60", 72", 84", 96" |

## SEMI CIRCULAR WINDOW WELLS



| Width X Projection         | Item Number | Steel Gauge | Available Depths                       |
|----------------------------|-------------|-------------|--|
| 37" Width x 16" Projection | WTR3716     | 20          | 12", 18", 24", 30", 36", 48"           |
| 40" Width x 20" Projection | WER4020     | 18          | 12", 18", 24", 30", 36"                |
| 46" Width x 20" Projection | WER4020     | 18          | 12", 18", 24", 30", 36", 48", 60", 72" |

## VENT WELLS

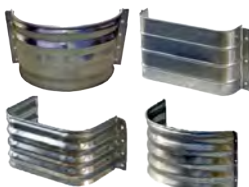

| Shape      | Width X Projection         | Item Number | Available Depths |
|------------|----------------------------|-------------|------------------|
| Square     | 16" Width x 4" Projection  | FVW16-4     | 11.5"            |
| Square     | 20" Width x 12" Projection | FVW12SQ     | 12"              |
| Semicircle | 20" Width x 8" Projection  | FVW2208-12  | 12"              |
| Semicircle | 20" Width x 12" Projection | FVW22012-12 | 12"              |

### Elongated Galvanized Window Wells

Hard to find sizes--8 widths, 8 different heights. Our most popular 40" width readily available. All dimensions are nominal inside dimensions.



| Width X Projection         | Item Number | Steel Gauge | Available Depths                       |
|----------------------------|-------------|-------------|--|
| 40" Width x 14" Projection | WAE4014     | 18          | 12", 18", 24", 30", 36", 48", 60", 72" |
| 46" Width x 18" Projection | WAE4618     | 18          | 12", 18", 24", 30", 36", 48", 60", 72" |
| 55" Width x 18" Projection | WAE5518     | 18          | 12", 18", 24", 30", 36", 48", 60", 72" |
| 59" Width x 18" Projection | WAE5918     | 18          | 12", 18", 24", 30", 36", 48", 60", 72" |
| 67" Width x 18" Projection | WAE6718     | 18          | 12", 18", 24", 30", 36", 48", 60", 72" |
| 71" Width x 20" Projection | WAE7120     | 18          | 12", 18", 24", 30", 36", 48", 60", 72" |
| 79" Width x 20" Projection | WAE7920     | 18          | 12", 18", 24", 30", 36", 48", 60", 72" |
| 91" Width x 20" Projection | WAE9120     | 18          | 12", 18", 24", 30", 36", 48", 60", 72" |

### White Egress Compliant Window Well

Our white window wells come in a wide variety of widths and depths. These wells reflect ambient light into your basement, making it a brighter, more livable space. Egress Ladders available for all well depths. We sell to Contractors and Homeowners--and delivery is direct to your home, business, or job site.



| Width X Projection         | Item Number | Steel Gauge | Available Depths                       |
|----------------------------|-------------|-------------|--|
| 42" Width x 36" Projection | WCS4236WH   | 18          | 12", 18", 24", 30", 36", 48", 60", 72" |
| 50" Width x 36" Projection | WCS5036WH   | 18          | 12", 18", 24", 30", 36", 48", 60", 72" |
| 55" Width x 36" Projection | WCS5536WH   | 18          | 12", 18", 24", 30", 36", 48", 60", 72" |
| 60" Width x 36" Projection | WCS6036WH   | 18          | 12", 18", 24", 30", 36", 48", 60", 72" |
| 67" Width x 36" Projection | WCS6736WH   | 18          | 12", 18", 24", 30", 36", 48", 60", 72" |
| 75" Width x 36" Projection | WCS7536WH   | 18          | 12", 18", 24", 30", 36", 48", 60", 72" |

### Decorative Stone Egress Compliant Window Well

These durable window wells greatly improve the view out your basement window! The stone look laminate is durable and minimize the corrugation of the steel. Egress Ladders available for all well depths.



| Width X Projection         | Item Number | Steel Gauge | Available Depths                       |
|----------------------------|-------------|-------------|--|
| 42" Width x 36" Projection | WCS4236SW   | 18          | 12", 18", 24", 30", 36", 48", 60", 72" |
| 50" Width x 36" Projection | WCS5036SW   | 18          | 12", 18", 24", 30", 36", 48", 60", 72" |
| 55" Width x 36" Projection | WCS5536SW   | 18          | 12", 18", 24", 30", 36", 48", 60", 72" |
| 60" Width x 36" Projection | WCS6036SW   | 18          | 12", 18", 24", 30", 36", 48", 60", 72" |
| 67" Width x 36" Projection | WCS6736SW   | 18          | 12", 18", 24", 30", 36", 48", 60", 72" |
| 75" Width x 36" Projection | WCS7536SW   | 18          | 12", 18", 24", 30", 36", 48", 60", 72" |

### Monarch Stone View Stif Back II Window Well

Monarch StoneView Window Wells are one piece metal egress window wells are available in multiple sizes. These sturdy wells will not shift or collapse due to their method of construction.



**MONARCH**

- ✓ Decorative finish + durable metal construction
- ✓ Variety of egress code compliant sizes

| Width | Projection | Item Number | Available Depths             |
|-------|------------|-------------|------------------------------|
| 42"   | 24"        | MCS4224SV   | 12", 24", 36", 48", 60"      |
| 55"   | 24"        | MCS5524SV   | 24", 36", 48", 60", 72", 84" |
| 67"   | 24"        | MCS6724SV   | 24", 36", 48", 60", 72", 84" |
| 79"   | 24"        | MCS7924SV   | 24", 36", 48", 60", 72", 84" |
| 42"   | 36"        | MCS4236SV   | 12", 24", 36", 48", 60"      |
| 49"   | 36"        | MCS4936SV   | 24", 36", 48", 60", 72", 84" |
| 55"   | 36"        | MCS5536SV   | 24", 36", 48", 60", 72", 84" |
| 67"   | 36"        | MCS6736SV   | 24", 36", 48", 60", 72", 84" |
| 79"   | 36"        | MCS7936SV   | 24", 36", 48", 60", 72", 84" |



### Plastic/Composite Window Wells

Composite egress size window wells are one-piece deluxe window wells that have built-in steps. These richly textured window wells are available in two widths to accommodate larger windows, and will not shift or collapse due to their construction method.

## PLASTIC / COMPOSITE WINDOW WELLS SIZING

| Inside Dimensions          | Outside Dimensions         | Item Number | Available Depths |
|----------------------------|----------------------------|-------------|------------------|
| 65" Width x 36" Projection | 71" Width x 40" Projection | STS7168     | 60", 72"         |
| 54" Width x 38" Projection | 60" Width x 42" Projection | STS6057     | 60", 72"         |

## How to measure to purchase window wells

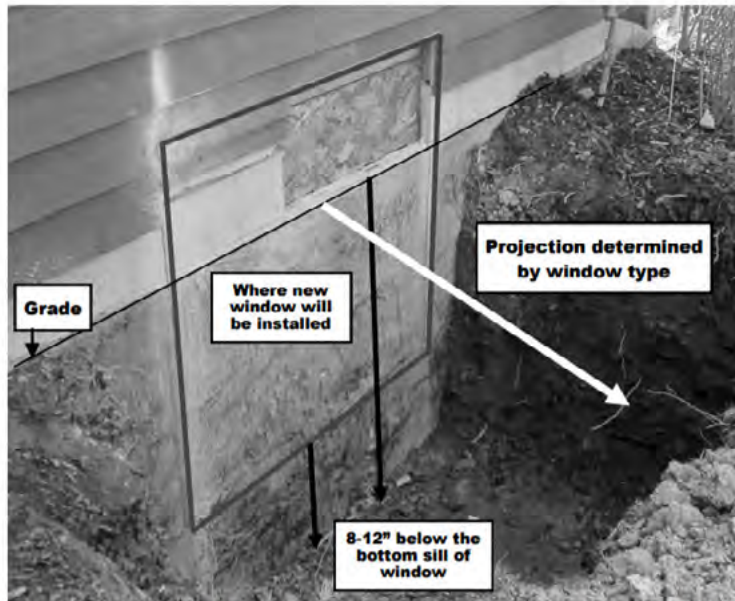

**Please consult local codes regarding window and window well installation.** The width of the window well needs to be the width of the window plus a few inches on either side. Projection to be determined by window type. Egress windows need at least a 36" projection in the USA. Depth into ground is determined by the depth of the window below grade plus 8-12".



**How to compensate for areas with high water flow**

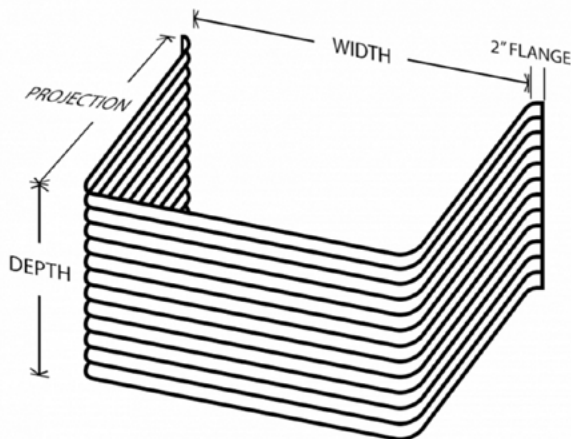

**When ordering a well, please remember:**

- We recommend a well that goes 8-12" deeper into the ground than the bottom sill of your window
- We recommend a well that is at least 2" wider on each side than your window's rough opening
- Window well sizes are measured to the inside dimensions and DO NOT include the 2" flange on each side of the well

**NEED HELP? CALL 1-888-650-WELL(9355)**  
**(OR EMAIL [INFO@WINDOWWELLEXPERTS.COM](mailto:INFO@WINDOWWELLEXPERTS.COM))**

**WINDOW WELL EXPERTS**

# EGRESS WINDOW KITS

OUR EGRESS WINDOW KITS INCLUDE:



**EGRESS WINDOW WELL**

Included is an Egress Code compliant window well that will meet any IRC standard.  
Minimum: 36" projection



**EGRESS BASEMENT WINDOW**

There are very strict standards when it comes to window size for basement egress. We'll help you get the perfect window for your situation.



**EGRESS LADDER**

Did you know wells greater than 44" in depth require a permanently attached ladder? We'll include the ladder needed for your specific well.



**COMPLIANT WINDOW WELL COVER**

To be Egress Code compliant, your window well cover must be able to be opened from the inside and outside with little force.

## WE TAKE THE GUESS WORK OUT OF BEING IRC EGRESS CODE COMPLIANT

Our experts have over 30 years experience helping contractors and homeowners meet their local Egress Code compliance no matter what the situation. We are well versed in International Residential Codes and know exactly what is required for emergency egress for your basement. **Questions?** Call 1-888-650-9355



Visit [WindowWellExperts.com/egress-window-kits](http://WindowWellExperts.com/egress-window-kits)

**NEED HELP? CALL 1-888-650-WELL(9355)**  
**(OR EMAIL [INFO@WINDOWWELLEXPERTS.COM](mailto:INFO@WINDOWWELLEXPERTS.COM))**

# EGRESS WINDOW KITS



# EGRESS LADDERS

## WindowWellExperts.com Brand Egress Ladders

Hook-Over



Hooks over the top of a metal well lip, can be bolted to the bottom with included hardware

Bolt-On



Bolts directly onto the inner part of the well with included hardware

For Concrete/Brick Wells



Extended hook to fit over an 8" concrete or brick window well ledge



**Monarch Egress Ladder**  
Available in Copper Vein.

| LADDER HEIGHT SIZING |                |              |
|----------------------|----------------|--------------|
| NO OF RUNGS          | OVERALL HEIGHT | TREAD HEIGHT |
| 3                    | 42 3/4         | 37 1/2       |
| 4                    | 54 3/4         | 49 1/2       |
| 5                    | 66 3/4         | 61 1/2       |
| 6                    | 78 3/4         | 73 1/2       |

### Window Well Egress Ladder sizing:

For all styles: Hook-Over, Bolt-On and ladders for Concrete/Brick wells

- 3 step ladder for wells 48" deep or less
- 4 step ladder for wells 52" - 62" deep
- 5 step ladder for wells 63" - 72" deep
- 6 step ladder for wells 73" - 84" deep
- 7 step ladder for wells 85" - 96" deep
- 8 step ladder for wells 97" - 108" deep No longer available.

All rungs are 12" apart, 16" wide, and the uprights are 12" apart.

Ladders for concrete/brick are intended to fit an 8" ledge

Visit [WindowWellExperts.com/window-well-accessories/egress-ladders/](http://WindowWellExperts.com/window-well-accessories/egress-ladders/)

**NEED HELP? CALL 1-888-650-WELL(9355)**  
**(OR EMAIL INFO@WINDOWWELLEXPERTS.COM)**



WINDOW WELL EXPERTS

# DECORATIVE LINERS

Decorate your basement  
window well with

## WINDOW WELL SCENES<sup>®</sup>

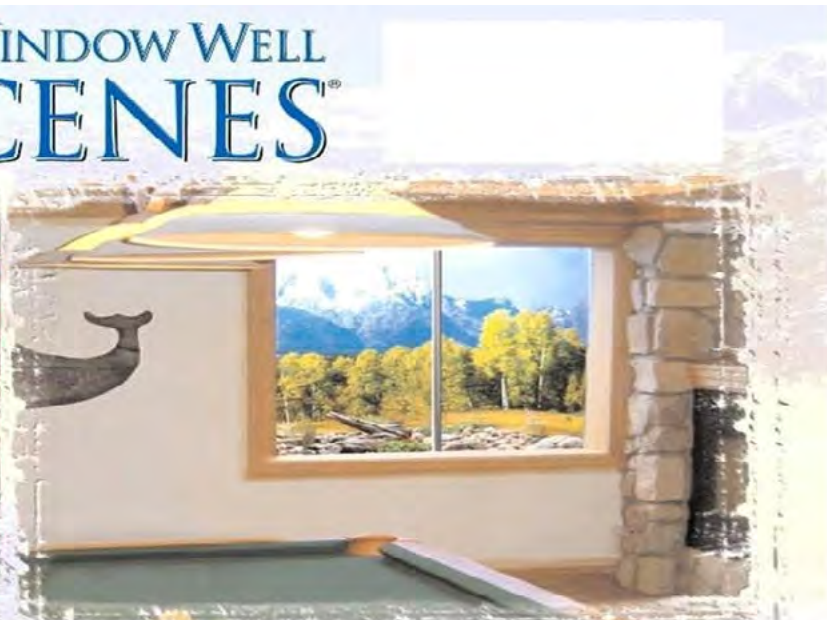

### Window Well Liners

- Heavy gauge vinyl
- High-Definition Graphics
- Weather and UV resistant
- Most scenes are available in 2 sizes
- Trims easily to your needed size with scissors
- **Over 24 decorative scenes** available!

- Weather resistant material with high-quality UV inks to prevent fading
- Includes peel-and-stick fasteners for easy DIY installation
- Can easily be trimmed with scissors to the exact size you need
- Conforms to the curve of your well

Visit [WindowWellExperts.com/window-well-liners](http://WindowWellExperts.com/window-well-liners)

**NEED HELP? CALL 1-888-650-WELL(9355)**

**(OR EMAIL [INFO@WINDOWWELLEXPERTS.COM](mailto:INFO@WINDOWWELLEXPERTS.COM))**

# BASEMENT WINDOWS

## SW Series Slider Basement Window - Vinyl



Basement slider windows have sashes and frames that are wept for superior water drainage to the outside. The half screen is removable from the inside.

- Available nominal wall thickness of 8".
- All vinyl frame is maintenance-free—no painting or rusting
- The window is poly-wrapped before pour to prevent any concrete from getting on it
- Sashes are removable from the inside
- Reversible is poured incorrectly. Header jamb and sill parts snap-in for correction
- 3/4" insulated Low-E glass is standard u-value of 0.37
- Sashes are double weather-stripped to protect from outside weather infiltration
- The following sizes: **SW4848 and SW6048 are egress sizes.**



## IN-SWING BASEMENT WINDOWS

- Meets Uniform Building Code for Egress
- Available in full and nominal wall thickness. (attach 2" extension for 10" wall)
- Welded sash with powder coated handles for ease of operation
- Available in standard and **custom sizes.**
- Fully braced with temporary wood bracing and fully wrapped with plastic film
- All Vinyl frame is maintenance free—No painting or rusting!
- 3/4" insulated Low-E glass for added thermal efficiency
- Sash is double-weatherstripped to protect from outside weather infiltration

Visit [WindowWellExperts.com/basement-windows](http://WindowWellExperts.com/basement-windows)

**NEED HELP? CALL 1-888-650-WELL(9355)**

**(OR EMAIL [INFO@WINDOWWELLEXPERTS.COM](mailto:INFO@WINDOWWELLEXPERTS.COM))**

# BUYING WINDOW WELL COVERS IS AN EASY 4 STEP PROCESS... IF YOU ARE READY... THEN CLICK BELOW:

**NEED HELP? CALL 1-888-650-WELL(9355)  
(OR EMAIL [INFO@WINDOWWELLEXPERTS.COM](mailto:INFO@WINDOWWELLEXPERTS.COM))**

## EASY 4 STEP PROCESS...

**1**  
**MEASURE YOUR WELLS**

*Print the Measuring Guide PDF and carefully measure your window wells, you'll need them for Step 2.*

**2**  
**GET A FREE QUOTE**

*Submit the Free Estimate Form with your measurements from Step 1 and your contact information. You will receive a custom quote within 48 hours.*

**3**  
**PLACE YOUR ORDER**

*After getting your quote, place your order over the phone by calling 1-888-650-9355. We accept all major credit cards.*

**4**  
**INSTALL YOUR COVERS**

*Included in your shipment is detailed instructions. Depending on the size of your well, most covers can be installed in less than 45 minutes!*

## Have Questions? Call 1-888-650-9355

# CUSTOMER TESTIMONIALS



**ROBERT S.**

“ Immediately made a difference with the moisture under my home!



**GEORGE M.**

“ I could not find anything that could stop me from getting melted snow in my basement or from heavy rains. This custom fitted window well was easy to order thanks to clear measuring instructions from you. Thank you, problem solved.



**LARRY L.**

“ Best covers ever! They keep my grandson and his toys from falling into the window wells. Nothing like these covers are available in the big box stores.



**HERMAN L.**

“ Totally professional experience. I am a new homeowner so my handyman skills are very limited. Bob and whole staff guided me in measuring (and re-measuring) and purchasing 3 sloped covers. Installation instructions were very clear and unbelievably simple. Very good quality product with strong steel stabilizer bar.



**CHARLES S.**

“ I'm very happy/satisfied/content with the window well covers – and so is my cat. Purrrrrrrrrrrrfect!!!



**BILL L.**

“ Great experience and product. Solved my problems with water looks good, perfect fit, and easy to install. Highly recommend.



**SHERRY B.**

“ WWE was very helpful and nice to work with.



**MICHAEL S.**

“ We went through two sets of the cheap Home Depot window well covers, which disintegrated within 1 year (like our neighbors). Spending more to get durable wells from Window Well Experts is well worth it!



**JOSEPH B.**

“ Kathy and Molly were excellent to work with. Both were very knowledgeable and helpful. I highly recommend them. After pricing our other companies I found them to be the most cost effective for my custom covers. So glad I find them. Great existence from beginning to end. The product is very good quality.



**ROBERT B.**

“ Great product custom fit to my well and works perfectly as you can see! No more worry of the dogs or kids falling in!

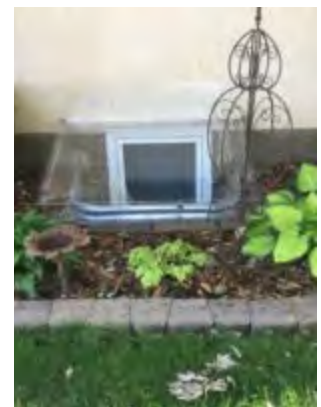

**TOM B.**

“ WWE took great care to make sure my cover for exactly as needed. Their customer service staff was very helpful. Cover looks, fits and works great!

**WINDOW WELL  
EXPERTS**

